

Jennifer Newman | **Drum planter** indoor/outdoor use



500dia x 600h mm
Weight 8 kg



400dia x 500h mm
Weight 5 kg

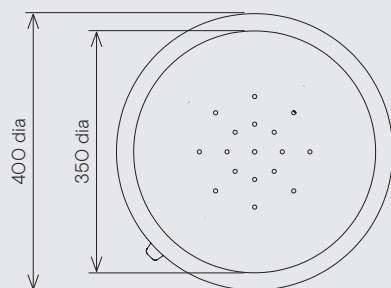
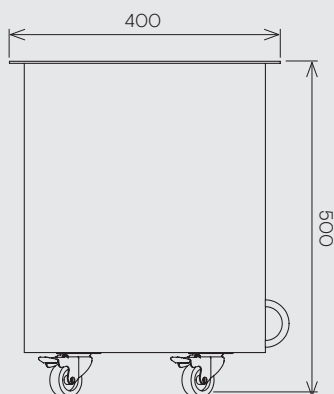

All dimensions are in mm.

Fine texture powder-coat finish providing:

Aluminium for long-life, will not rust.
Anti-bacterial and Volatile-Organic-Compound free.
Minimal maintenance, easily cleaned.
Lockable castors.

Other benefits and features:

Security hoop included.
Drainage holes as standard.
Liners for indoor use **not** provided.
13 standard colours,
others on request (see separate reference sheet).